

ALGE SWIM2000

Architectural Guideline

ALGE
TIMING

ALGE-TIMING GmbH & Co
Rotkreuzstrasse 39
A-6890 Lustenau
Telefon: +43 5577-85969
Fax: +43 5577-85969
e-Mail: office@alge-timing.com
Internet: www.alge-timing.com

Table of contents

1.	Introduction	Page3
2.	Swimming Pool	Page3
2.1	Length 50(25) m pools	Page3
2.2	Dimensional Tolerances	Page3
2.3	Depth	Page3
2.4	Walls	Page3
3.	The Timing-System	Page5
3.2	Mobile wiring	Page6
3.3	Pictures of a mobile wiring	Page7
3.3	Permanent Wiring	Page8
3.3.1	Pre Installation	Page8
3.3.1.1	Pre installation of local company	Page8
3.3.1.2	Permanent pre-installation-diagram	Page9
4.	Touch pads	Page10
4.1	General mounting-possibilities	Page10
4.1.1	Concrete Pool	Page10
4.1.1.1	Concrete-Pool	Page10
4.1.1.2	Concrete-Pool with shifted Gutter	Page11
4.1.1.3	Stainless-Steel Pool with rollout Gutter	Page12
4.1.1.4	Stainless-Steel Pool with Starting-Block-Bench	Page12
5.	Starting-Block	Page13
5.1	SO2 Standard Starting block	Page13
5.2	Starting-Block SO2-X	Page14
6.	SWR 2	Page15
7.	Score board-Systems	Page16
7.1	Numeric score board	Page16
7.1.1	GAZ4 nxx Bistabile Electromagnetic 7-segment	Page16
7.1.1.1	Character size	Page16
7.2	Alphanumeric score boards	Page17
7.2.1	Dot-Matrix-Systems	Page17
7.2.2	LED-Matrix-Systems	Page18

1. Introduction

This guideline should help the architects to include a preplanning for an electronic-timing and scoring-system into a competitive aquatic center.

With the SWIM2000 Timing-System ALGE developed a milestone for the organization of swimming-competitions. We are proud to present the first timing-system which can operate network-based with the Meet-Management-Software and with other additional Software-Packets like Speaker-Info, Live-Internet transfer and much more.

2. Swimming Pool

All recommendations under point 2 are regulated by the FINA.

Be sure to check the new constitution on the FINA homepage www.fina.org.

Link for [Facility-rules](#)

2.1 Length 50(25) m pools

When touch panels of Automatic Officiating Equipment are used on the starting end, or additionally on the turning end, the pool must be of such length that ensures the required distance of 50.0 (25.0) meters between the two panels.

Lanes shall be at least 2.5 meters wide, with two spaces of at least 0.2 meter outside of the first and last lanes.

For ALGE Touch pads add 11 mm on each side equipped with Automatic Officiating Equipment. See also Touch pad!

2.2 Dimensional Tolerances

Against the nominal length of 50.0(25.0) meters, a tolerance of plus 0.03 meter in each lane minus 0.00 meter on both end walls at all points from 0.3 meter above to 0.8 meter below the surface of the water is allowed. These measurements should be certified by a surveyor or other qualified official, appointed or approved by the Member in the country in which the pool is situated. Tolerances cannot be exceeded when touch panels are installed.

2.3 Depth

A minimum depth of 1.35 meters, extending from 1.0 meter to at least 6.0 meters from the end wall is required for pools with starting blocks. A minimum depth of 1.0 meter is required elsewhere.

2.4 Walls

End walls shall be parallel and form right angles to the swimming course and to the surface of the water, and shall be constructed of solid material, with a non slip surface extending 0.8 meter below the water surface, so as to enable the competitor to touch and push off in turning without hazard.

Gutters may be placed on all four walls of the pool. If end wall gutters are installed, they must allow for attachment of touch panels to the required 0.3 meter above the water surface. They must be covered with a suitable grill or screen.

The complete walls should have no projecting parts like underwater-lights, speakers or other things! The touch pads need a complete even wall.

See Touch pads!

2.5 Starting platform

Starting Platforms shall be firm and give no springing effect. The height of the platform above the water surface shall be from 0.5 meter to 0.75 meter. The surface area shall be at least 0.5 meter x 0.5 meter and covered with nonslip material. Maximum slope shall not be more than 10°. The platform shall be constructed so as to permit the gripping of the platform by the swimmer in the forward start at the front and the sides; it is recommended that, if the thickness of the starting platform exceeds 0.04 meter, grips of at least 0.1 meter width on each side and 0.4 meter width in the front be cut out to 0.03 meter from the surface of the platform. Hand grips for the forward start may be installed on the sides of the starting platforms. Hand grips for backstroke starts shall be placed within 0.3 meter to 0.6 meter above the water surface both horizontally and vertically. They shall be parallel to the surface of the end wall, and must not protrude beyond the end wall. The water depth from a distance of 1.0 meter to 6.0 meters from the end wall must be at least 1.35 meters where starting platforms are installed.

See also Starting-Block.

3. The Timing-System

Some Manufacturer of Timing-System will tell you that only their system is approved by the FINA! **But the FINA doesn't approve any timing-systems.** The Timing-System can be from any supplier and has to fit the FINA-Constitution which can be found on the Internet under following LINK: <http://www.fina.org/const.html>
ALGE-TIMING guarantees that all parts are conforming to the FINA-Constitution.

Independent accuracy-test:

RÉPUBLIQUE
NEUCHÂTEL



ET CANTON DE
(SUISSE)

OBSERVATOIRE ASTRONOMIQUE ET CHRONOMÉTRIQUE DE NEUCHÂTEL

CERTIFICAT DE VÉRIFICATION

délivré à

ALGE Timing Lustensu (A)

pour le garde-temps : SWC
No 9913001

Intervalle de temps					
effectif			mesuré		
0h	0m	0.000	0h	0m	0.000
2	0	0.000	1	59	59.9992
4	0	0.000	3	59	59.9986
6	0	0.000	5	59	59.9981
8	0	0.000	7	59	59.9976
10	0	0.000	9	59	59.9972
12	0	0.000	11	59	59.9969
14	0	0.000	13	59	59.9966
16	0	0.000	15	59	59.9963
18	0	0.000	17	59	59.9961
20	0	0.000	19	59	59.9958

Température : 21°C

Position : horizontale

P. Le directeur de l'Observatoire,

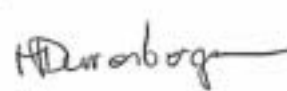

NEUCHÂTEL, le 16 mars 1999

3.2 Mobile wiring

The mobile wiring is the cheapest way to connect all modules together and it is also the safest. All cabling can be made with a mobile cable-set.
For competition-use the complete cabling must be set, this takes about half an hour for 1 person. Additionally you can hide the cabling under an anti-slip-carpet which is very useful at competitions.

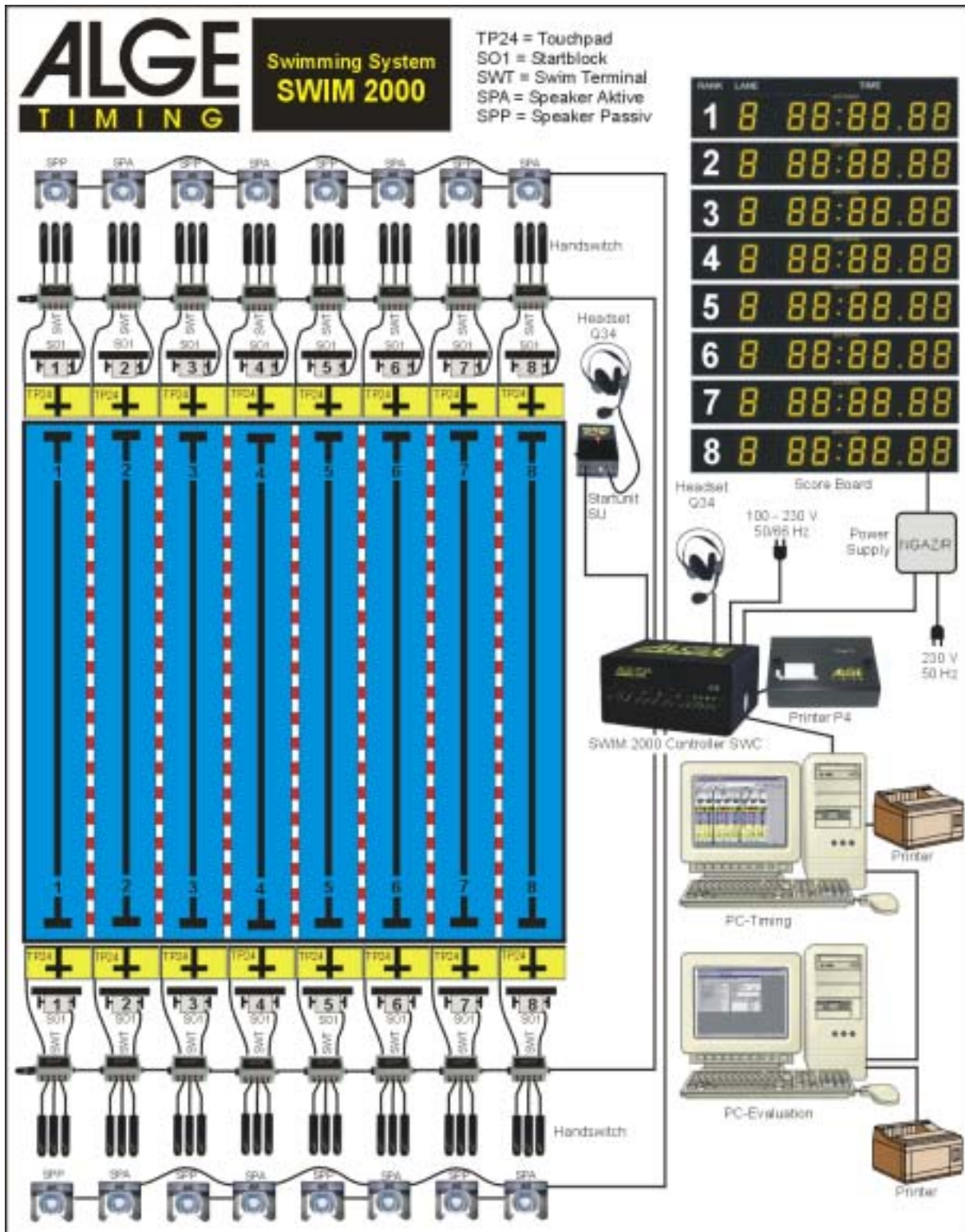

3.3 Pictures of a mobile wiring



3.3 Permanent Wiring

For the permanent wiring it is very important to solder and completely seal all connections because of the aggressive Pool-Area.

ATTENTION! Seal all soldered connections with a non-moisture-absorbing sealant like SIKAFLEX221! Most Silicone-sealants are moisture-absorbing and the connections will corrode in a few years!

It is important to make the decision for permanent wiring early in the planning process. The architect has to provide the building with all necessary conduits and installations for a permanent wiring. Please provide us with architectural plans for review and preplanning! For a perfect permanent wiring we recommend to use the ALGE starting block SO2.

All connections for manual buttons and touch pads are built in.

[See also Starting-Block.](#)

3.3.1 Pre Installation

ALGE-TIMING is a producer and supplier of timing-systems. On request an ALGE-technician can provide supervision on all installations concerning the timing and scoring-system.

3.3.1.1 Pre installation of local company

- ☞ supply and install specific conduits
- ☞ install or supply and install touch pad-fasteners
- ☞ crane, lift or scaffolding to assist ALGE-technician in mounting score board

3.3.1.2 Permanent pre-installation-diagram

In this diagram you see the maximum installation for an aquatic center for following sports: Swimming, Waterpolo, Diving and Synchronized-swimming
All conduits should be supplied with pull-wires!

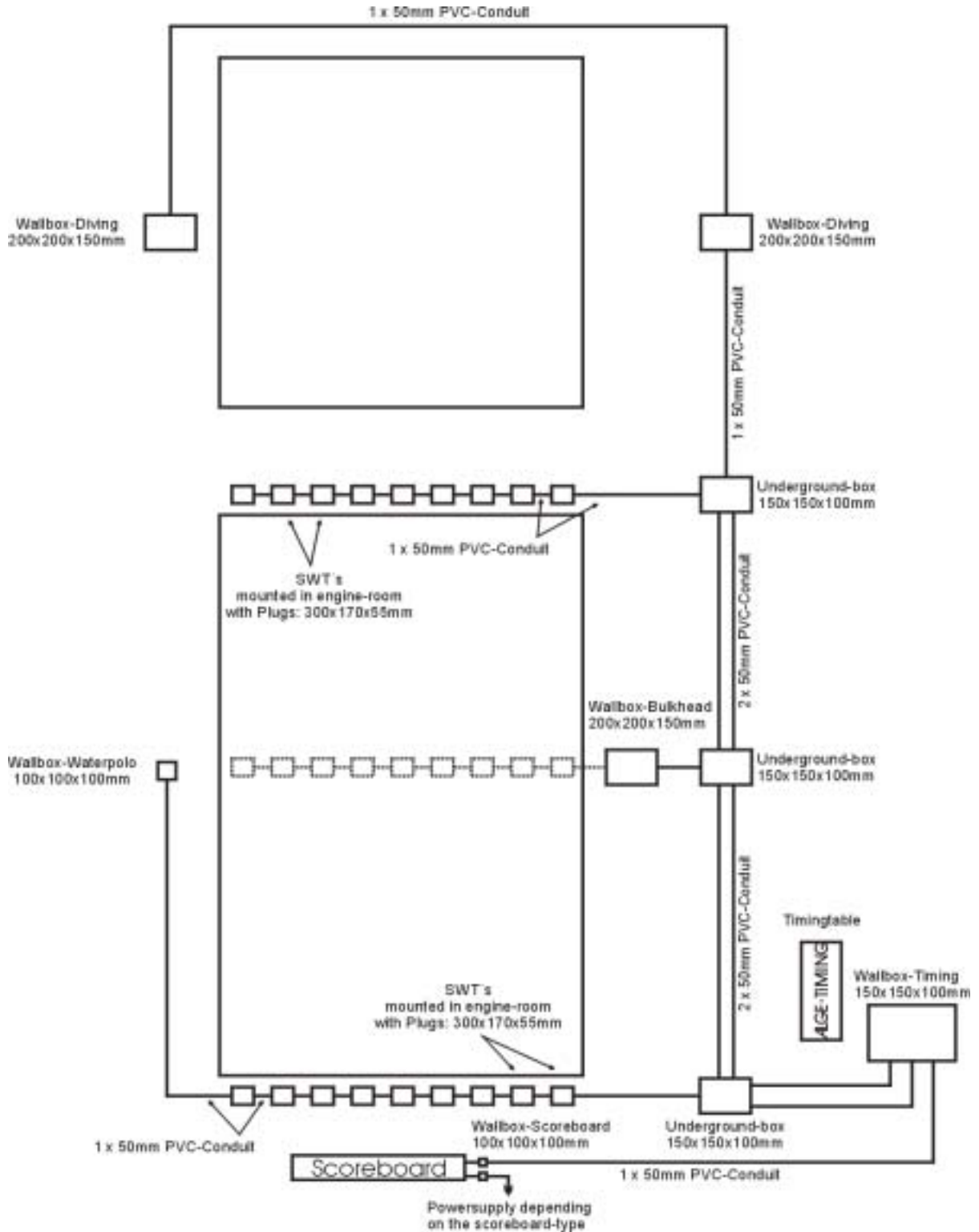

4. Touch pads

4.1 General mounting-possibilities

The mounting of the touch pad is one of the most important points for a satisfied installation of a timing system for swimming. It is important that the installation of the touch pads into the pool is easy to do for the personal who are operating the timing-system.

ALGE offers different solutions for any need.

4.1.1 Concrete Pool

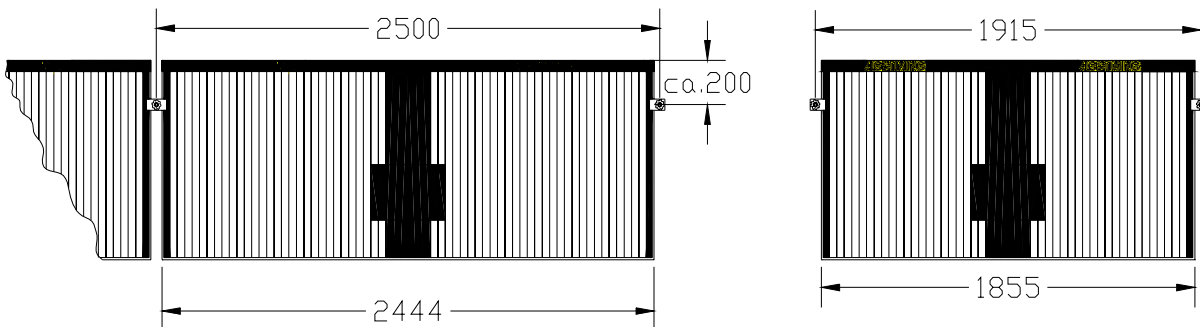

4.1.1.1 Concrete-Pool

Here is an example how to realize the mounting of the touch pads in a concrete-pool.

To the right side you see how the mounting of the touch pad is working in detail. This is a very effective system of touch pad-mounting. You need no tools for installation of the touch pad and the touch pad has a perfect fit at the wall.

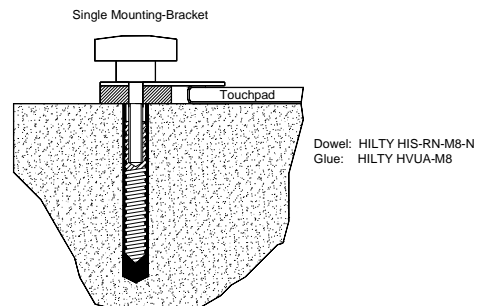

An other possibility to mount the touch pad is to manufacture special race-line-fasteners. If there is about 50 mm up the hole for the race-line a M8 thread in the metal-plate you can mount the touch pad at this M8 thread with the standard-fasteners.

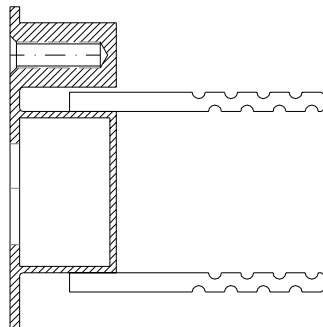
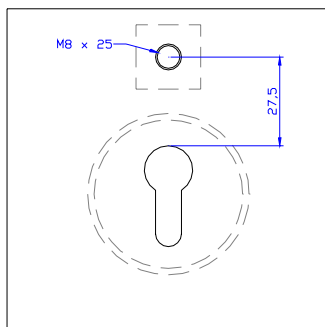

4.1.1.2 Concrete-Pool with shifted Gutter

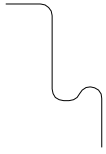

If the pool is equipped with a Gutter-Type like shown in the figure to the left you need additional turn-pads which extends 300 mm from the water level in an even surface with the wall.

ALGE-TIMING can provide you also with these turn-plates, but we recommend that the manufacturer of the pool construct this turn-plates with all necessary connecting-elements fitting to the pool.

The manufacturer of the turn-plates should equip the turn-plates with the M8-thread for the touch pad-fasteners and with the race-line-suspension.

Referee to the dimensions described in point 4.1.1



4.1.1.3 *Stainless-Steel Pool with rollout Gutter*

Stainless-Steel-Pools with rollout gutters need additional turn-plates which extends 300 mm from the water level in an even surface with the wall.

ALGE-TIMING can provide you also with these turn-plates, but we recommend that the manufacturer of the pool construct this turn-plates with all necessary connecting-elements fitting to the pool.

The manufacturer of the turn-plates should equip the turn-plates with the M8-thread for the touch pad-Fasteners and with the race-line-suspension.

Referee to the dimensions described in point 4.1.1.1
You need the high version of the [starting block SO 2](#).



4.1.1.4 *Stainless-Steel Pool with Starting-Block-Bench*

If there is a stainless-steel-pool with starting-block-bench we recommend welding-nuts at all required positions. See point 4.1.1.1

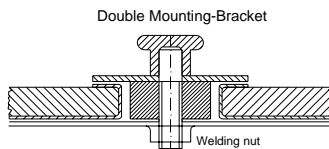

5. Starting-Block

ALGE has two different types of starting-blocks. The SO 2 with a height of 337 mm at the front and the SO 2-EX with a height of 637 mm at the front.

As we produce the starting-blocks for each order we can provide you also with custom-made designs. Please ask for details.

5.1 SO2 Standard Starting block

The start-block SO2 is well designed with an integrated solid, accurate relay-judging-detector against the FINA-constitution. No changes are required at the Starting-Block for public use.

The top-part is designed with a special anti-slip structure.

Custom designs are available on request.

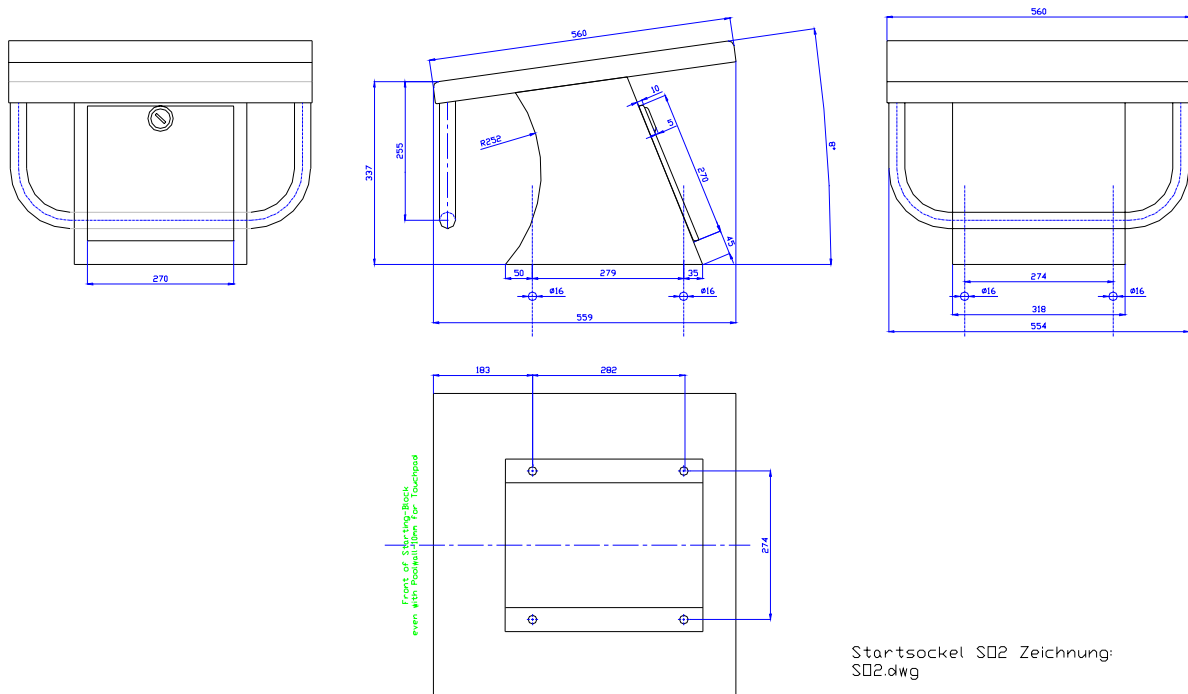

Startsockel SO2 Zeichnung: SO2.dwg



5.2 Starting-Block SO2-X

The start-block SO2-EX is also designed for public use and for competitive swimming without any changing. This type has a height at the front of 637 mm and concerns to the FINA constitution.

Custom-Designs are available on request.

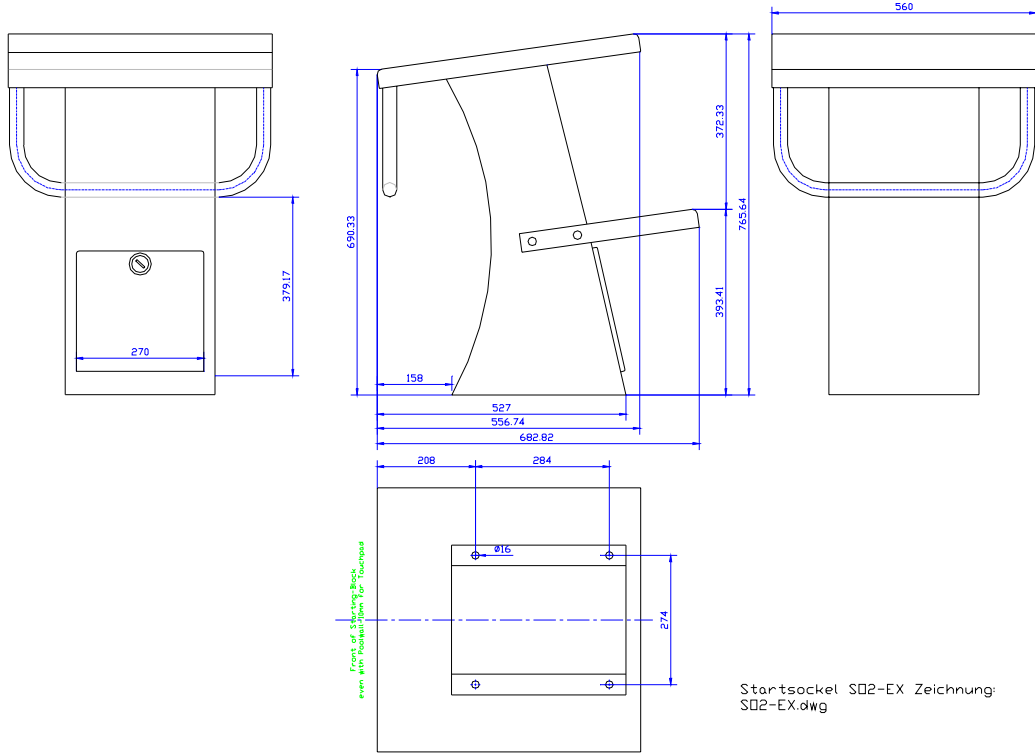

6. SWR 2

The SWR 2 is a mobile Relay-Judging Detector. With different mounting-options the SWR 2 will fit on any existing starting-block. The SWR 2 is designed only for competitive swimming, you have to remove them for public use of the pool.



7. Score board-Systems

In general there are 2 different display-systems. The numeric-score board and the alphanumeric-score board.

The numeric score boards can show only numbers. With the alphanumeric score boards you can also show names and depending on the model you can show pictures.

7.1 Numeric score board

Two different technologies are used for numeric score boards.

ALGE-TIMING is producing only the type with bistabile segments.

The technology with bulbs is obsoleted.



Beispiel einer mobilen Anzeigetafel mit 8 Zeilen.

7.1.1 GAZ4 nxx Bistabile Electromagnetic 7-segment

ALGE-TIMING is producing 3 different sizes of this display-boards. See below!

They are constructed with bistabile electromagnetic digits.

Advantages of the numeric bistabile display

- ☞ best visibility also in direct sunlight
- ☞ low power consumption
- ☞ possibility of battery-operating
- ☞ low in price
- ☞ easy handling (no additional PC is used)

Disadvantages of the Dot-Matrix

- ☞ only numbers can be displayed
- ☞ slow in displaying (no running 1/10)

7.1.1.1 Character size

We recommend the 25 cm character size for most swimming-pools. This is also the recommendation of the FINA. See FINA-HOME PAGE!

- ☞ 15 cm, DIN legibility 75 m
- ☞ 25 cm, DIN legibility 125 m
- ☞ 45 cm, DIN legibility 225 m



Single-Digit

7.2 Alphanumeric score boards

Alphanumeric score boards are available in different technologies. The following chapter will give you an overview of the used technologies and their advantages.

7.2.1 *Dot-Matrix-Systems*

All Dot-Matrix-Displays from ALGE-TIMING are custom-made.

They are available in a Dot-Size from 5 mm up to 30 mm and different resolutions.

This technology is used also in coaches to show the destination or other informations

Advantages of the Dot-Matrix

- ☞ good visibility with direct sunlight
- ☞ low power consumption
- ☞ easy handling with some restrictions without additional PC

Disadvantages of the Dot-Matrix

- ☞ always one color, no shades
- ☞ slow in displaying (no running 1/10)



Picture of a mobile Dot-Full-Matrix:

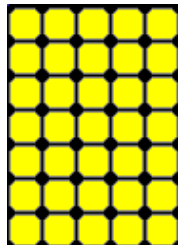

Single Element 5 x 7 Dots

7.2.2 *LED-Matrix-Systems*

ALGE-TIMING can supply you with all common LED-Display systems.
From 1 color numerical display up to a full-color video-wall.



For detailed informations about the specific products please contact us.



Notice: